

The All New  
**TRAVELLER**  
3350 WB



  
**BS II/III**  
compliant

  
**FORCE**  
**12**   
FREE SERVICES  
3 LACS / 3 YEARS  
UNMATCHED WARRANTY

## SALIENT FEATURES

- ▶ Originally designed and produced by Mercedes Benz AG Germany as T1 Transporter, it is now manufactured in India by Force Motors as the Traveller.
- ▶ Monocoque body structure provides total safety and car like ride quality. Cathodic Electrodeposition of primer coat ensures superior corrosion protection and enhances paint gloss retention.
- ▶ Interiors are roomy and elegant. High roof version offers clear standing height enabling easy internal movement.
- ▶ NVH re-engineered to deliver significant reduction of noise, vibrations & harshness in the passenger area.
- ▶ Ideally suitable for Inter & Intra City Travel.
- ▶ A good investment for Tours & Travels, Corporates, Airlines, Contractors etc.
- ▶ Greater safety on account of improved four piston front disc brakes and larger dia drum brakes in the rear.
- ▶ **OPTIONAL FITMENTS:**  
Air Conditioning, Power Steering, Sliding Door



Wider Wind screen for better visibility



All Forward Facing  
Standard Seats (12 + D / 14 + D)



Clear Standup Height of 6 feet.

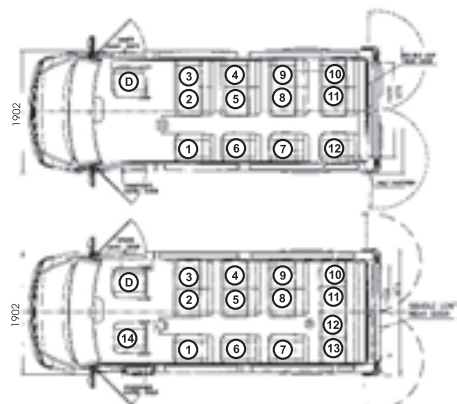

## TECHNICAL SPECIFICATIONS

### ENGINE

Model	: TD 2650 FTI TD-2650 FTI (BS-III) ED
Type	: 4-Cylinder, DI, TCIC
Emission Compliance	: BS-II, BS-III
Displacement	: 2596 cc
Max. Output	: 76 HP @ 3200 rpm / 82 HP @ 3200 rpm
Max. Torque	: 195 Nm @ 1800-2000 rpm / 215 Nm @ 1800-2000 rpm

### TRANSMISSION

Type	: Synchromesh
No. of Gears	: 5 Forward & 1 Reverse (5th gear - overdrive)

### AXLES

Front	: Dead Rigid I-Beam (Reverse Elliot type)
Rear	: Live Rigid

### SUSPENSION

Front	: Semi Elliptical Leaf spring with hydraulic telescopic shock absorbers & Anti roll bar
Rear	: Semi Elliptical Leaf spring with hydraulic telescopic shock absorbers

### STEERING

Type	: Mechanical / Power Steering (Optional)
------	---

Turning Radius	: 6.5 metres
----------------	--------------

### BRAKES

Service Brakes	: Hydraulic - Dual circuit (Vacuum Assisted)
Front	: Four piston disc brake with wear indicator
Rear	: Drum brake
Parking Brake	: Mechanical on rear wheels

### WHEELS & TYRES

Size	: 215 / 80 R 14 / 215 / 75 R 15
------	------------------------------------

### DIMENSIONS (mm)

Wheel Base	: 3350
Overall Length	: 5415
Overall Width	: 1975
Overall Height	: 2550
Overhang front	: 900
Overhang Rear	: 1165
Ground Clearance	: 210
Fuel Tank Capacity	: 70 Litres

### WEIGHTS (kg.)

Max. Permissible FAW	: 1490
Max. Permissible RAW	: 2020
Max. Permissible GVW	: 3510

<b>SEATING CAPACITY</b>	: 12+D & 14+D
-------------------------	---------------

## FORCE MOTORS LIMITED

Mumbai Pune Road, Akurdi, Pune - 411 035

Visit us at : [www.forcemotors.com](http://www.forcemotors.com)

Toll Free No. : 1800-2333-000

Authorised Dealer :

**NOTE** : On account of continuous Research and Development, specifications are subject to change.  
The data included herein is to be regarded as approximate.  
Accessories shown may not necessarily be part of standard equipment.